

EN

INSTALLATION  
AND  
USER GUIDE

**KODSAN**



INSTALLATION, USE AND MAINTENANCE OF THE DEVICE SHOULD BE DONE AS DESCRIBED IN THIS MANUAL OTHERWISE THE PRODUCT WILL NOT BE COVERED BY WARRANTY.



DO USE an automatic type maximum 8 bar safety valve according to TS EN 1487 : 2016 standard. If the automatic type safety valve conforming to TS EN 1487: 2016 standard is not installed on the device, it is defective or the connection is not made correctly, the device is not covered by the warranty.



In order to use the product safely during and after the warranty period, the water you will use is required to be conditioned according to the limit values allowed in the WHO REGULATIONS FOR HUMAN CONSUMPTION WATERS and World Health Organization Guidelines for Drinking-Water Quality, which was published in the Official Gazette dated 07.03.2013 and numbered 28580. If the water used in your device does not comply with the relevant regulations, standard values and limit values (EPA, WHO, etc.) given in documents belonging to internationally accepted organizations, your product will not be covered by the WARRANTY COVERAGE. Some limit values are provided as an example on page 31.



DO THE INSTALLATION to a qualified firm according to the connection scheme that corresponds to the model of the product you have purchased.



MAKE SURE that the product is completely filled with water. DO CHECK the sealing of all connections and pipes.



After you have completely filled your device with water, OPEN THE HOT WATER TAP to remove the air in the product.



Electrical connections for electrical products are to be made by qualified electrician.



Optionally, products with electrical resistances must be GROUNDED by qualified electrician.



For standard KEB series (electric water heater) product, it SHOULD ALWAYS HAVE A LEAK CURRENT RELAY in the electrical feed line. At least 6mm grounding cable must be connected to the panel to feed the products and these cables must be installed in accordance with the "Grounding Regulations for Electrical Installations" with a separate copper grounding spar or galvanized sheet on the existing installation/fitting.



In electrical products, the cable sections for the power supply line are given in page 7. DO USE a HALOGEN-FREE cable, which provides the relevant cable section for your product.



Electrical panels, electrical resistances and other electrical equipment failures are OUT of the warranty.

2	A. Device Settlement & Installation Principles	18	B.12 KGA Galvanized Accumulation Tank
3	A.1. Control / Safety Equipment	19	B.13 KCB Combi Buffer Tank
5	A.2. Volumetric Mounting Distances	20	B.14 KCB-S Single Serpentine Combi Buffer Tank
6	B. Installation Schemes	21	B.15 KBT-B Buffer Tank
6	B.1 KEB Electric Water Heater	22	B.16 KBT-S Single Serpentine Buffer Tank
8	B.2 KBS / KBS-B Basic Single Serpentine Water Heater	23	B.17 KBT-D Double Serpentine Buffer Tank
9	B.3 KBD / KBD-B Basic Double Serpentine Water Heater	24	B.18 KBT-CB Buffer Tank
10	B.4 KXS Single Row Serpentine Heat Pump Water Heater	25	B.19 KBT-C Buffer Tank with Baffle Plate
11	B.5 KXD Double Row Serpentine Heat Pump Water Heater	26	B.20 Installation Scheme Icons
12	B.6 KCS Single Copper Coil Serpentine Water Heater	27	C. Periodic Maintenance - Cleaning
13	B.7 KCD Double Copper Coil Serpentine Water Heater	28	C.1. Corrosion Protection
14	B.8 KSS Horizontal Serpentine Water Heater	29	C.1.1. Magnesium Anode Change
15	B.9 KSC Horizontal Double Wall Water Heater	30	C.1.2. Magnesium Anode Life Simulation
16	B.10 KSO Solar Water Heater	31	C.2. Domestic Water Criteria
17	B.11 KAT Enamelled Accumulation Tank	32	D. About Production / User Faultable Products

DO THE INSTALLATION to a qualified firm according to the connection scheme that corresponds to the model of the product you have purchased.

- Products are shipped with wooden pallets for transportation purposes. It should be disassembled before assembly.
- For the installation of the product, it is necessary to build a base on a solid / stable floor with the strength to bear the weight of the water heater.
- In the place where the product is to be installed, it is necessary to determine the location of the installation by providing the necessary interventions and discharging fields that can be done in case of product breakdown or change.
- Your device should be placed in a closed or non-freezing location. Your product is designed for use at ambient temperatures of + 5-50 degrees Celsius. Products used outside of this temperature range and outside conditions are not covered by the warranty.
- In order for your product to be able to operate efficiently, the installation must be made exactly as indicated on the scheme and the capacity of the heat sources must be selected according to the need for hot water. The product is not covered by warranty due to inefficient operation or physical damage due to installation errors.
- The device is not covered by the warranty if the automatic type safety valve conforming to TS EN 1487: 2016 is not installed, damaged or improperly.
- Precautions should be taken against the fire and flood on the area where the product is installed. Our company is not responsible for any equipment malfunctions or contingency.

Safety equipment: To prevent the drinking water temperature from exceeding 95 °C, the control and safety devices must be installed and operated by the user according to the following order:

- i) Thermostatic control device,
- ii) Energy-cut device,
- iii) Temperature, pressure relief valve / safety relief valve,

**Safety Valve** : In case of high pressure in the product, the water heater drains the water.

**Expansion Tank** : It is used to regulate the pressure fluctuations that can occur in the system.

**Filter (dirt separator)** : It is used to keep undesirable substances in the particle which may be present in the liquid entering the system.

**Valve** : It is used as an installation element that allows water flow in the system or stops the flow.

**Pump** : It is used to circulate the liquid used in the system.

**Manometer** : It is used to show the pressure value in the system.

**Thermometer** : It is used to see the temperature of the liquid in the system.

**Pressure Reducer** : It is absolutely necessary to install a pressure reducer in the connection line so that the water pressure on the line does not rise above the maximum allowable pressure of the device.

**Check Valve** : It allows the liquid moving in the system to flow in the desired direction, reverse flow of liquid is prevented.



**“AN AUTOMATIC TYPE MAX. 8 BAR SAFETY VALVE COMPLY TO TS EN 1487: 2016 STANDARD MUST BE USED FOR INSTALLATION OF THE DEVICE.”**

The water expands when heated. The amount of water expansion according to temperature is shown in the table and graphic below .

For example; At a temperature increase of 50 ° C, the volume of water increases by 1.19%.This water has to be evacuated. Water can not be compressed like air. If the expanding water does not go out of the water heater, it presses the shaft and explodes the water heater at the weakest point.

T   °C	d   kg/lt	V   kg/lt	Expansion   %
0	0.9998	1.0002	0
10	0.9996	1.0004	0.02
20	0.9982	1.0018	0.16
30	0.9956	1.0044	0.42
40	0.9922	1.0079	0.77
50	0.9880	1.021	1.19
60	0.9832	1.071	1.67
70	0.9777	1.0228	2.26
80	0.9718	1.0290	2.88
90	0.9635	1.0359	3.57
100	0.9583	1.0435	4.33
110	0.9519	1.0515	5.13
120	0.9431	1.0603	6.01

### Expansion Tank Application

The closed expansion tank volume to be installed on the cold water inlet side of the device should be selected at least 10% of the device volume. The expansion tank can operate up to 8 bar and the pre-pressure should be set below 10% of the operating pressure. The most important point to pay attention to in the equipment equipments is the connection of the automatic safety valve and expansion tank to the system. Always do install the expansion tank and the safety valve between the device and the valve. **ALWAYS DO CHECK** the pre- pressure of the expansion tank twice a year.

Volume   liter	Unit	100	160	200	300	400	500	800	1000	1500	2000	2500	3000
ØD	mm	490	590	590	700	750	750	900	1000	1120	1260	1460	1460
A	mm	875	875	875	875	875	875	875	875	875	875	875	875
B	mm	1125	1125	1125	1125	1125	1125	1125	1125	1125	1125	1125	1125
Min. Ceiling Height	mm	1430±10	1475±10	1920±10	1810±10	2500±10	2850±10	3150±10	3270±10	3500±10	3430±10	3400±10	3820±10

WATER EXPANSION ACCORDING TO TEMPERATURE DIFFERENCE

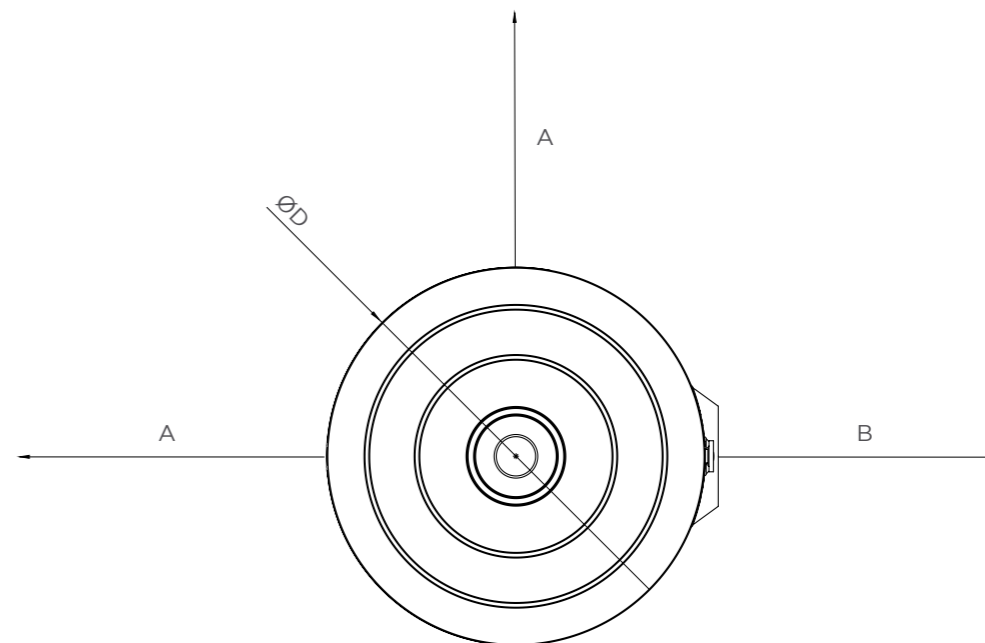
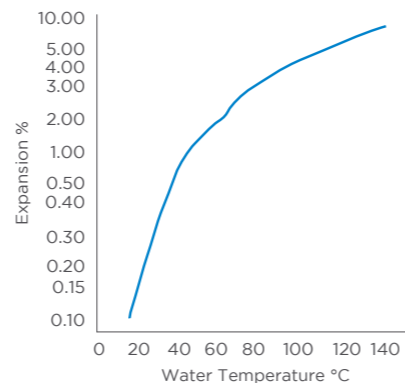

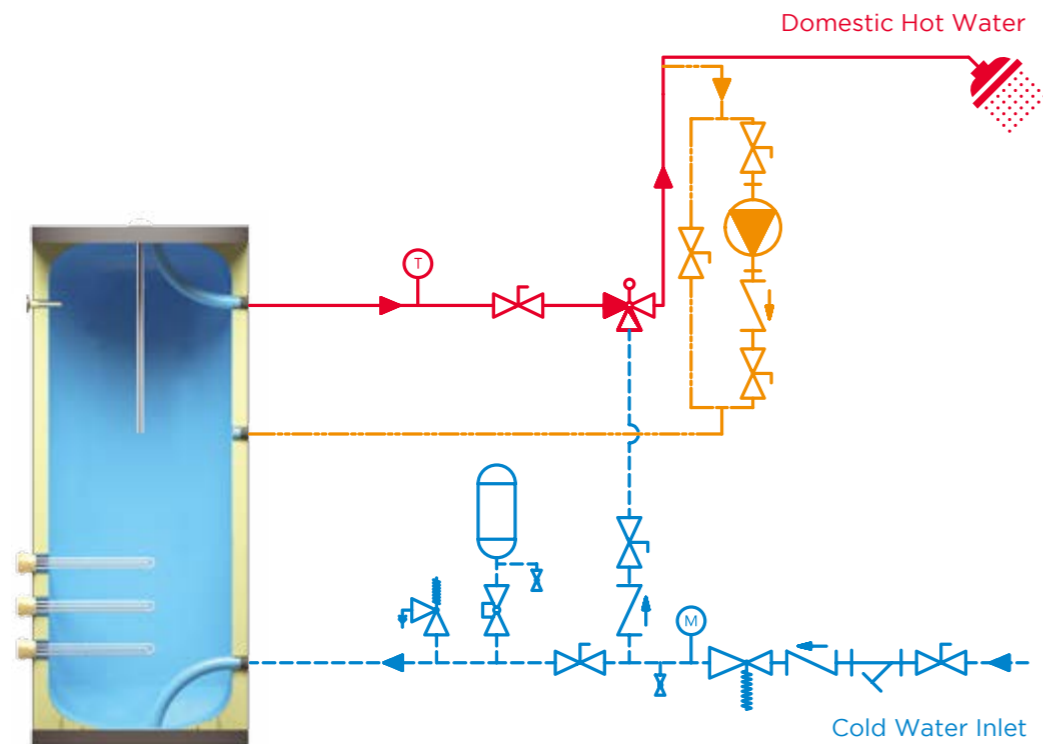

Panel Type	Max. Power	Unit	Max. Current	Unit	Cable Metrics < 25m	Cable Metrics > 25m
1 x 7,5 kW	7,5	kW	12,0	A	4x4 mm NYY	Please Consult
1 x 10 kW	10	kW	16,0	A	4x4 mm NYY	
1 x 15 kW	15	kW	24,0	A	4x6 mm NYY	
2 x 7,5 kW	15	kW	24,0	A	4x6 mm NYY	
2 x 10 kW	20	kW	32,0	A	4x6 mm NYY	
2 x 15 kW	30	kW	48,0	A	4x10 mm NYY	
3 x 7,5 kW	22.5	kW	36,0	A	4x6 mm NYY	
3 x 10 kW	30	kW	48,0	A	4x10 mm NYY	
3 x 15 kW	45	kW	72,1	A	4x16 mm NYY	
4 x 7,5 kW	30	kW	48,0	A	4x10 mm NYY	
4 x 10 kW	40	kW	64,0	A	4x16 mm NYY	
4 x 15 kW	60	kW	96,1	A	4x25 mm NYY	
>4 x ..kW	Please Consult					

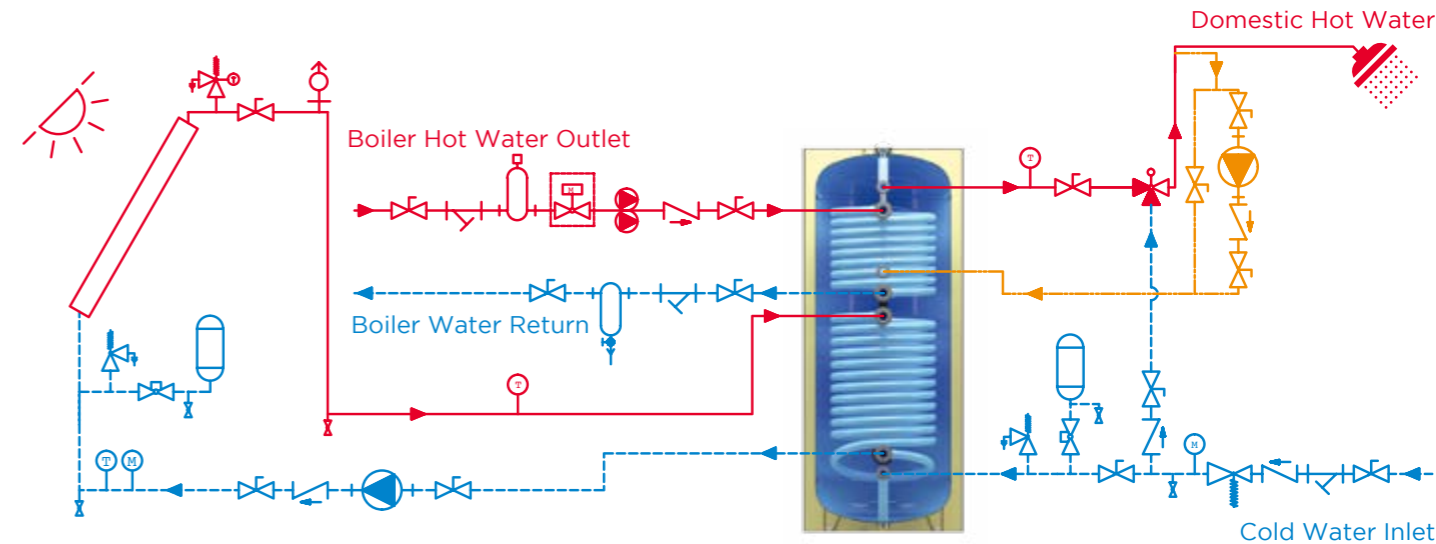
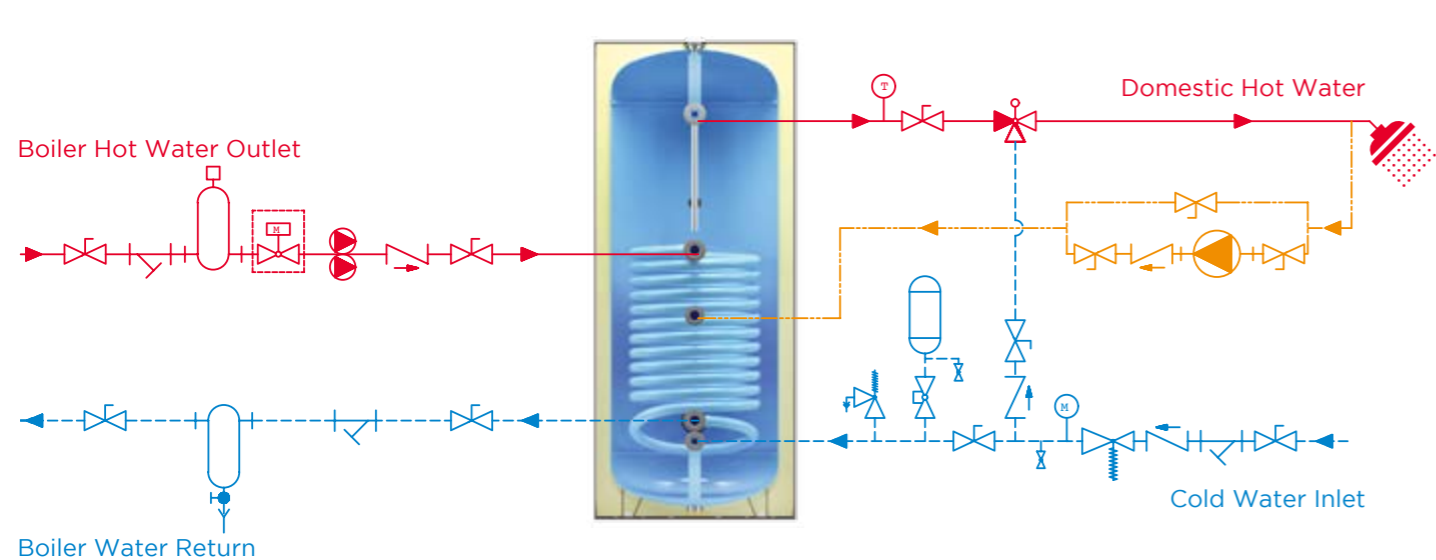

Product Type		Maximum Safety Valve Opening Pressure
KBS Single Serpentine Water Heater	Pro	8 bar
KBS-B Basic Single Serpentine Water Heater	Basic	4 bar

 Max. 8 bar automatic safety valve must be used.

Product Type		Maximum Safety Valve Opening Pressure
KBD Double Serpentine Water Heater	Pro	8 bar
KBD-B Basic Double Serpentine Water Heater	Basic	4 bar

 Max. 8 bar automatic safety valve must be used.

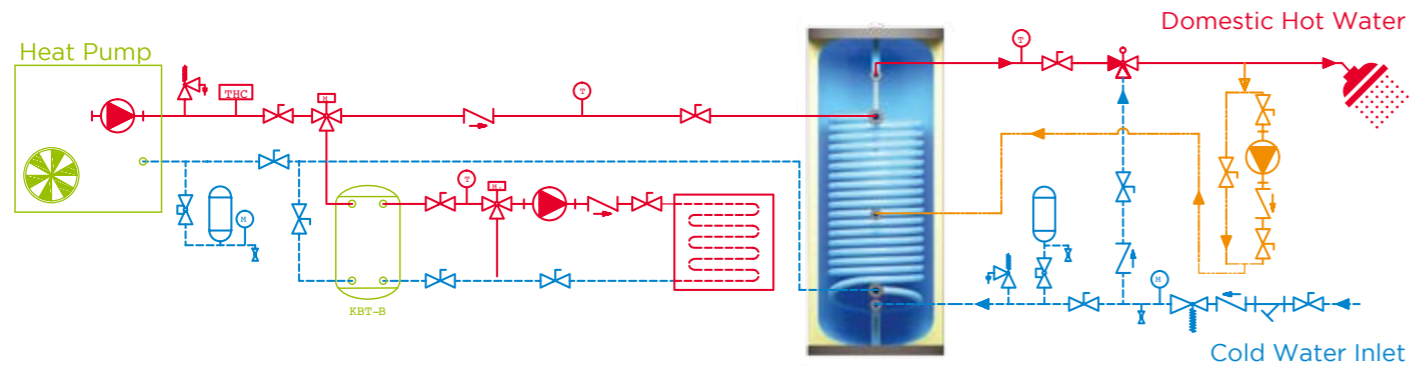

Max. 8 bar automatic safety valve must be used.

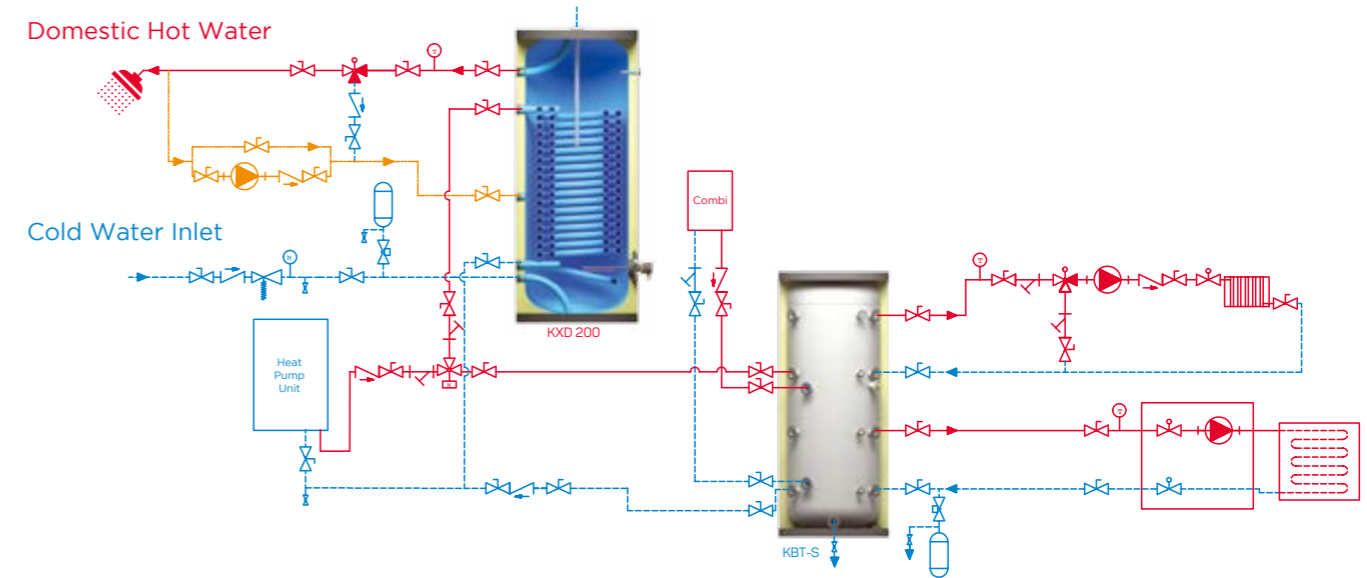

Max. 8 bar automatic safety valve must be used.

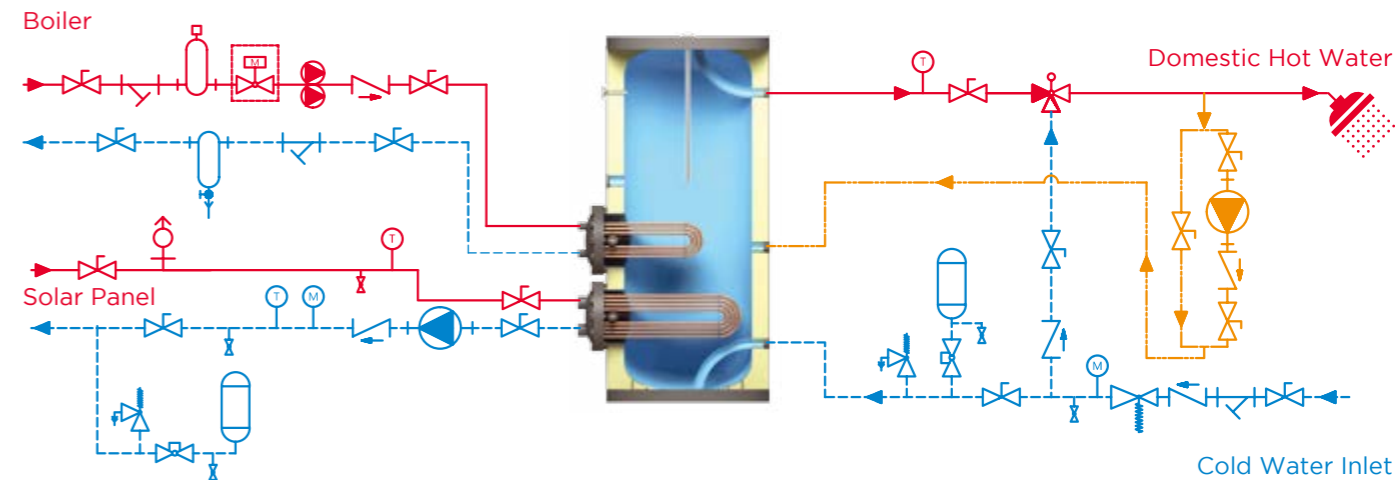
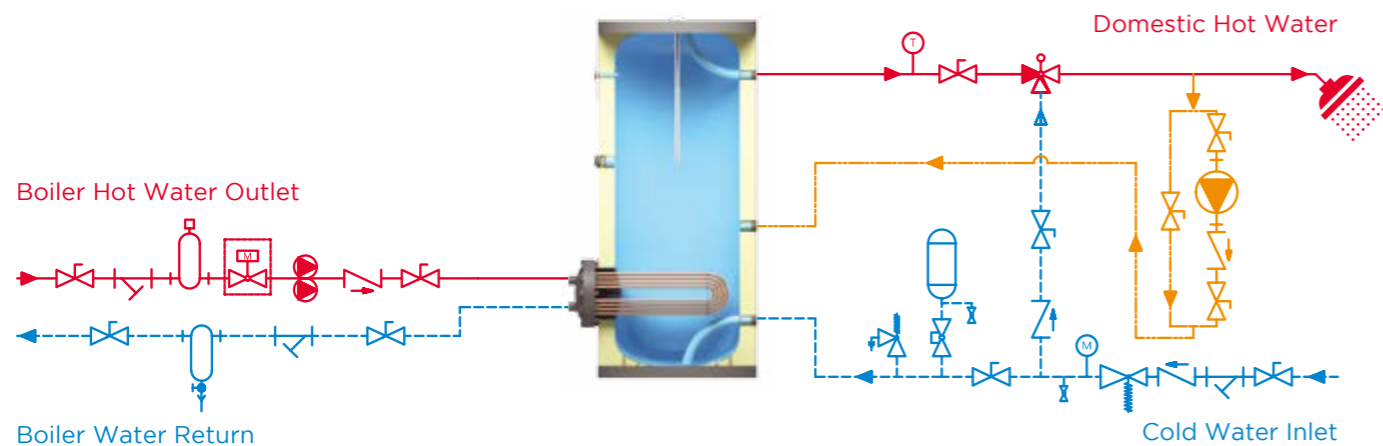

**!** Max. 8 bar automatic safety valve must be used. The maximum steam pressure of the serpentine (heater fluid side) should be 0.5 bar.

**!** Max. 8 bar automatic safety valve must be used. The maximum steam pressure of the serpentine (heater fluid side) should be 0.5 bar.



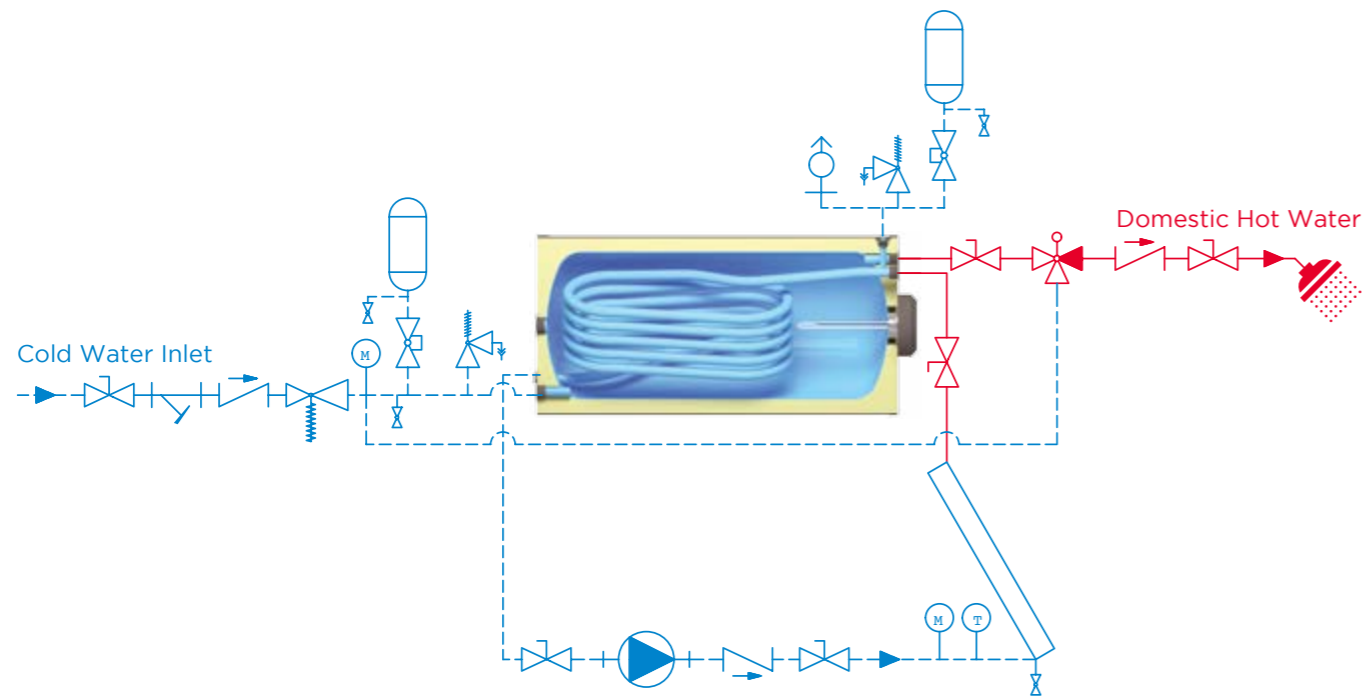

Max. 8 bar automatic safety valve must be used.

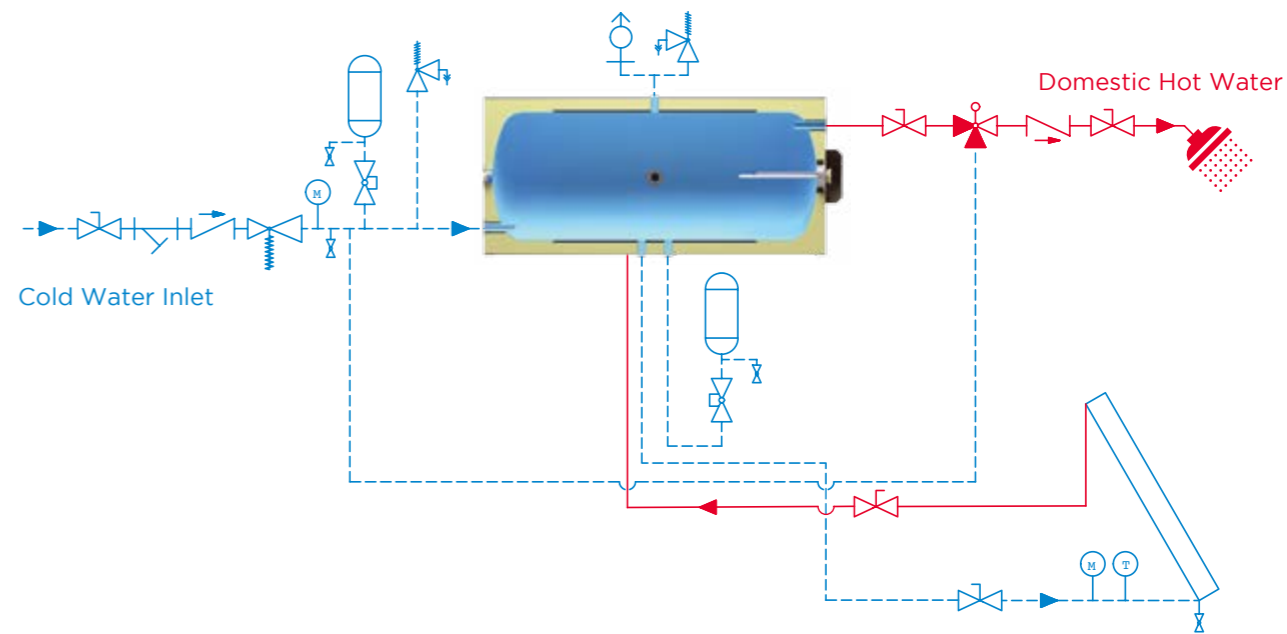

Max. 8 bar automatic safety valve for domestic water inlet and max. 1 bar automatic safety valve for internal wall must be used.

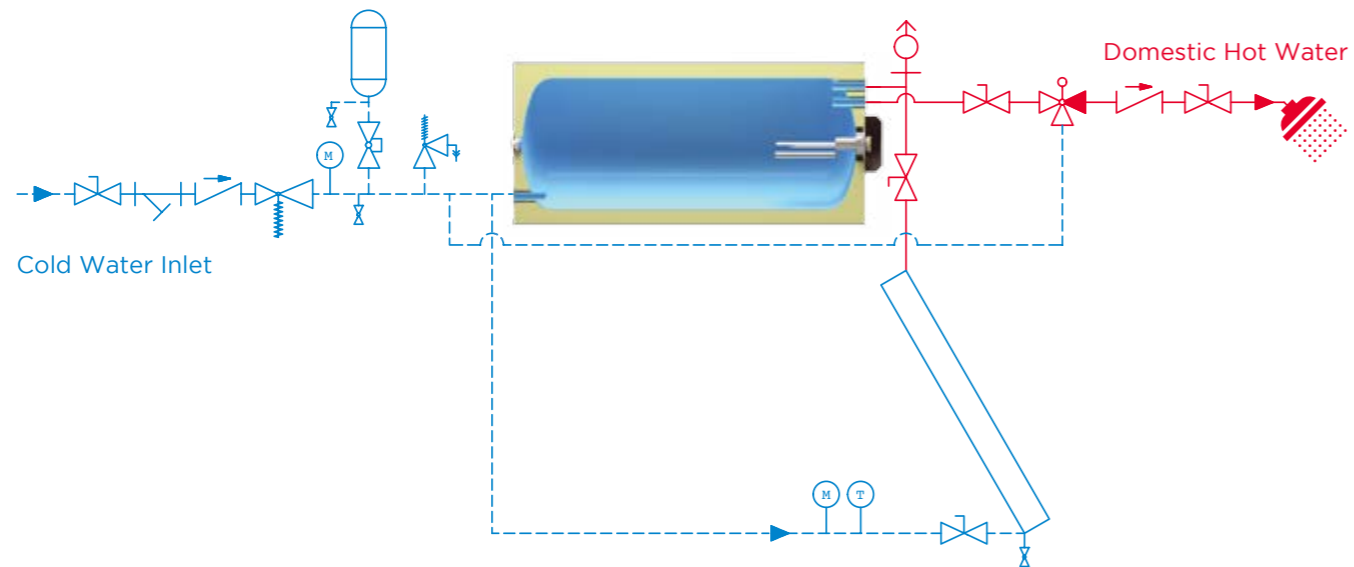

Max. 8 bar automatic safety valve must be used.

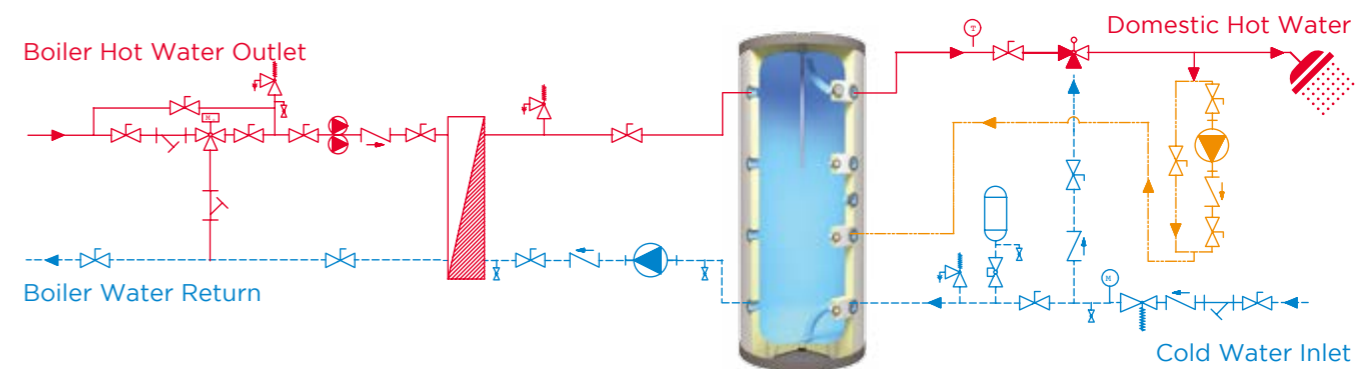

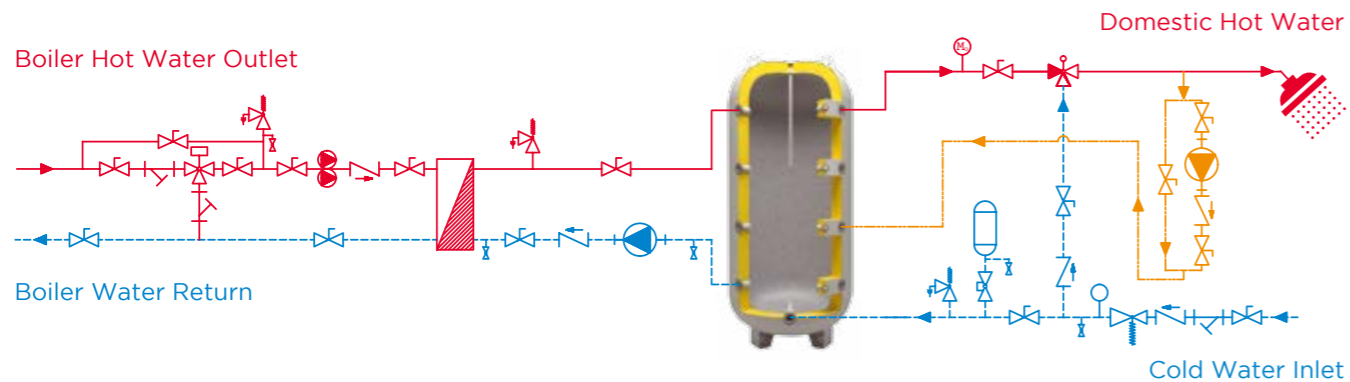

Max. 8 bar automatic safety valve must be used.

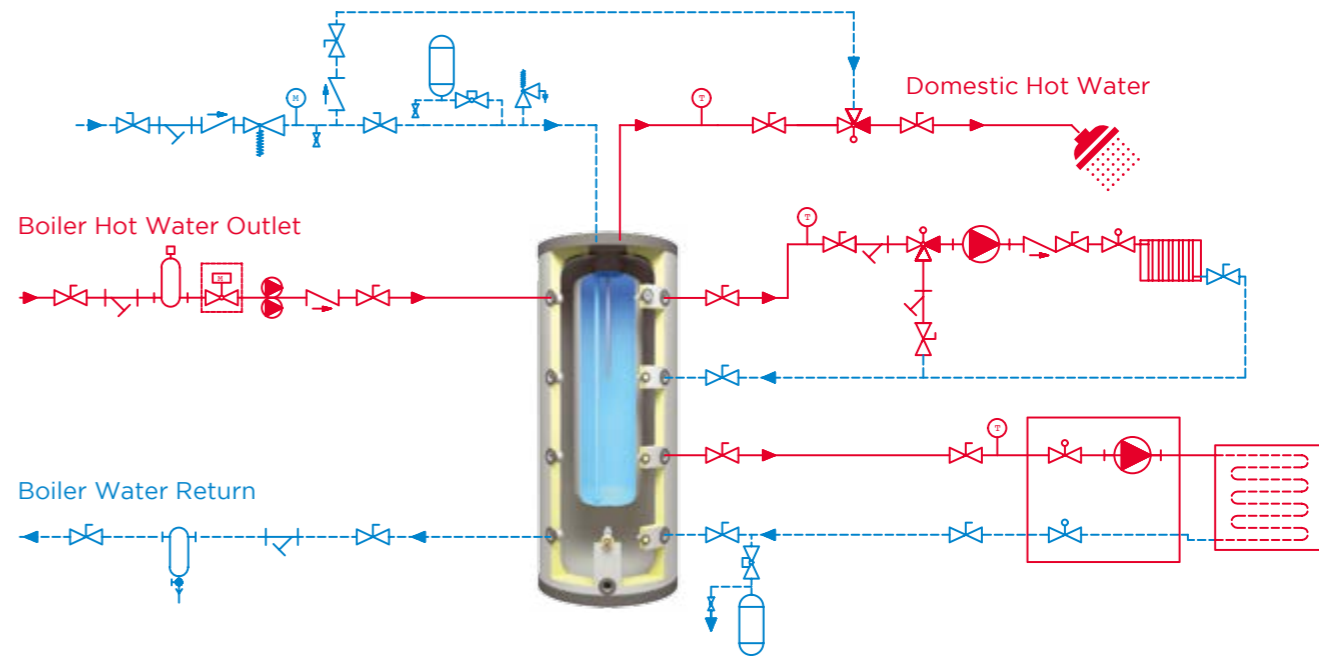

Product Type	Operating Pressure	Maximum Safety Valve Opening Pressure
KGA Galvanized Accumulation Tank	10 Bar	8 bar
	16 Bar	12 bar

 Max. 8 bar automatic safety valve must be used.



 It is necessary to use maximum 8 bar for the cold water inlet of the inner body and an automatic safety valve for the maximum 4 bar for the cold water inlet of the outer body.

 Before activating Combi Water Heaters, first the inner tank should be filled and pressurized then the outer tank should be filled. When the water is going to be flushed please do it first from the outer tank and secondly from the inner tank.

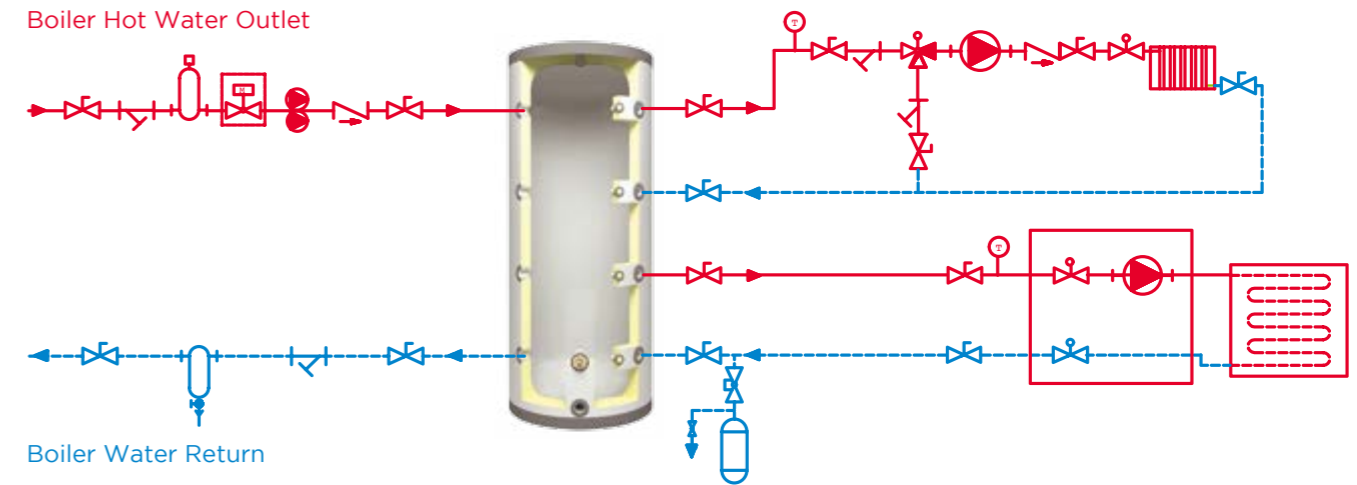
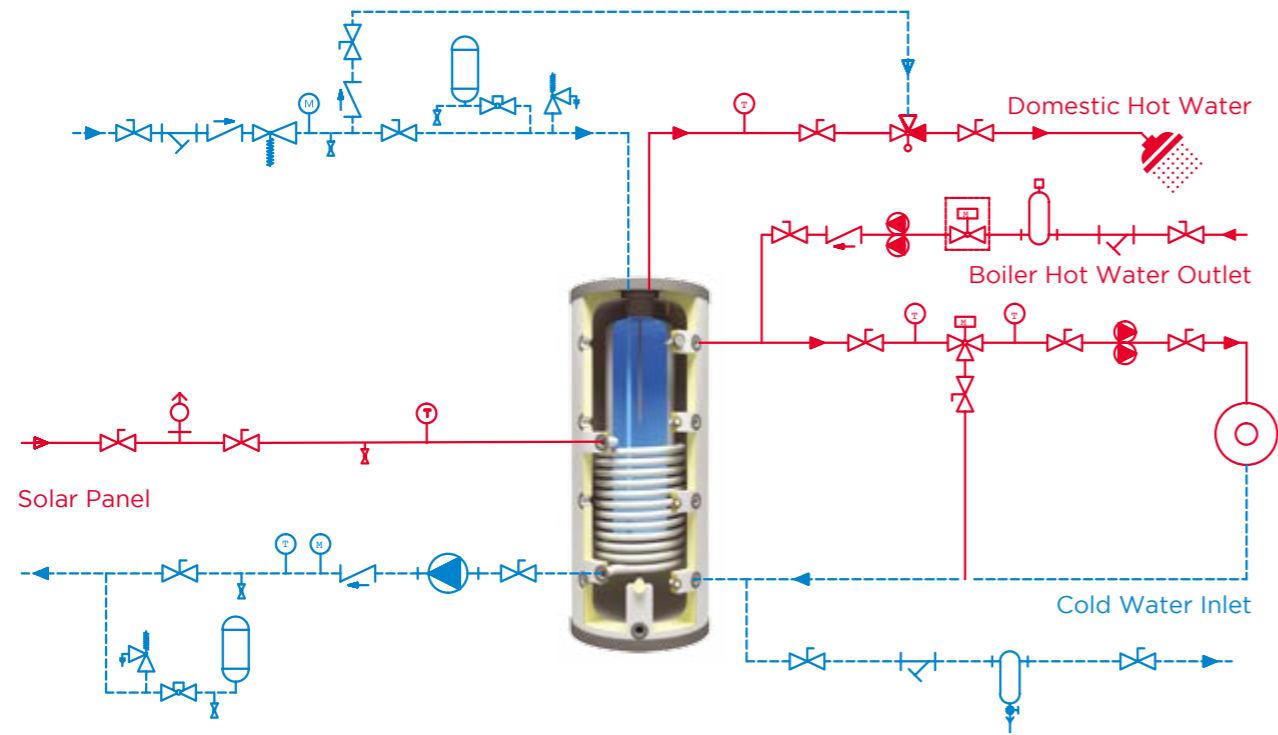





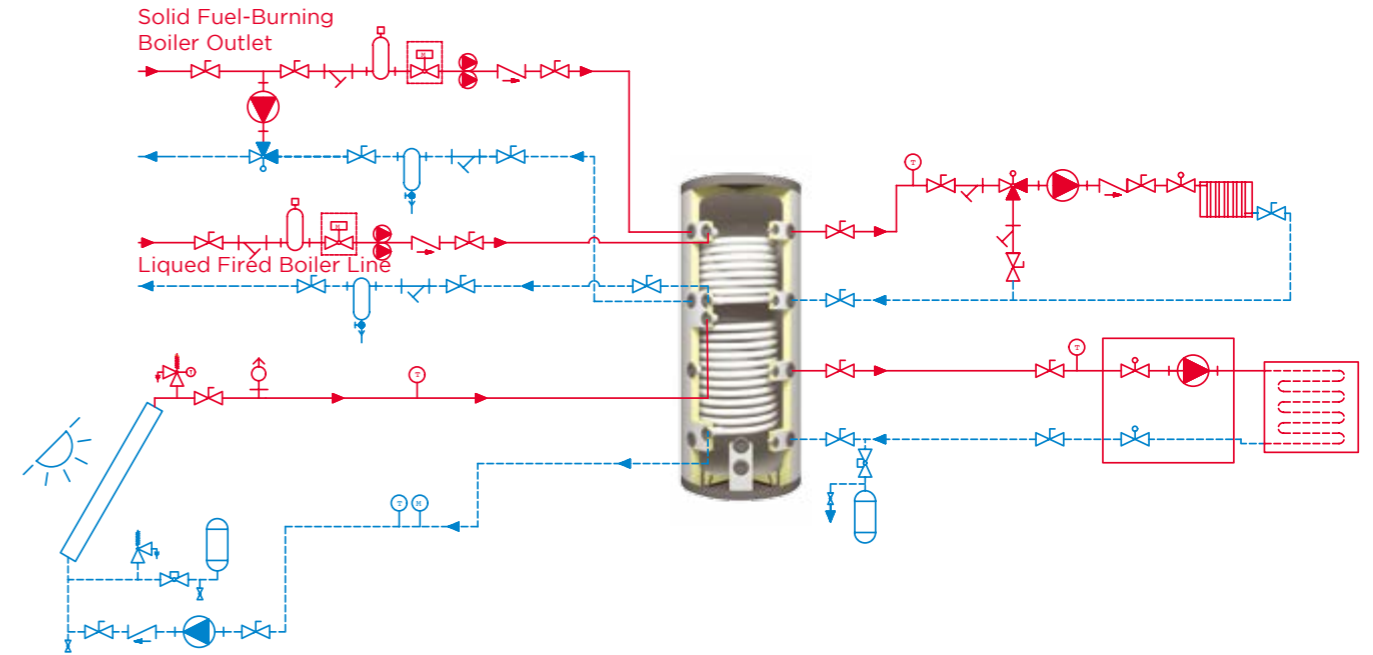
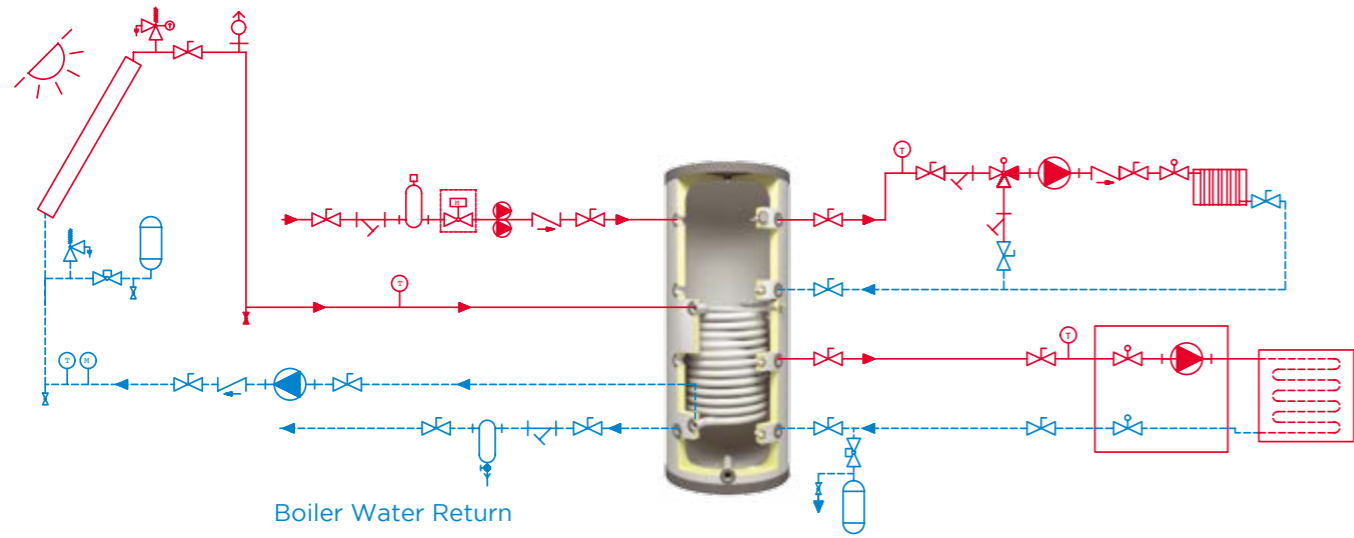

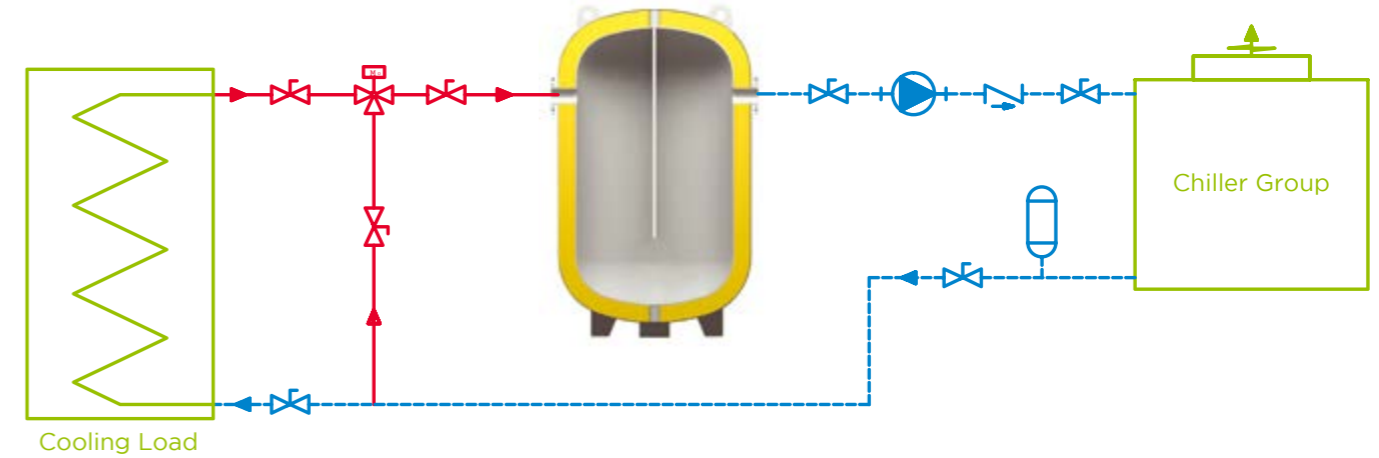
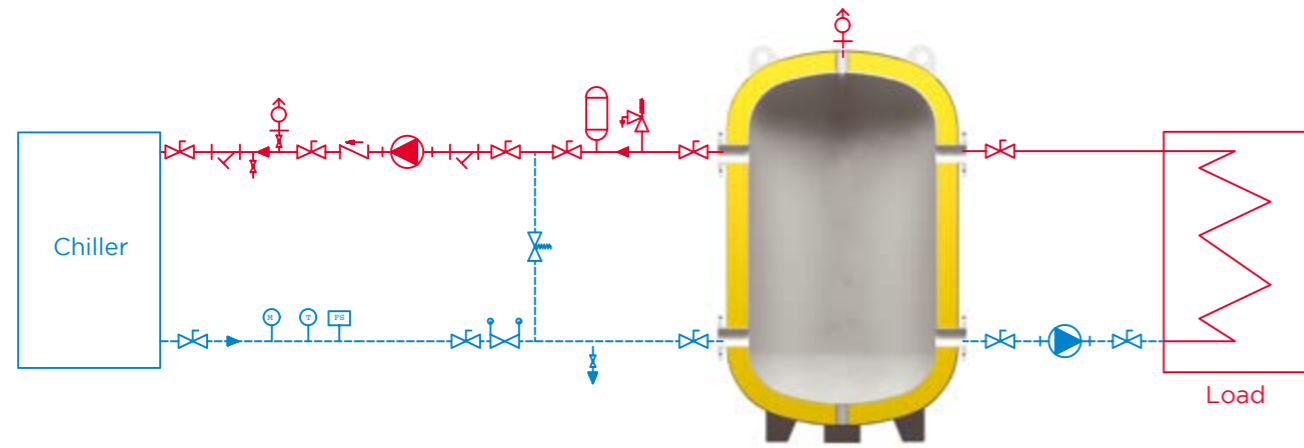



















Max. 8 bar automatic safety valve to internal body cold water inlet and max. 4 bar automatic safety valve to external body cold water inlet is required.

**!** When the boiler is commissioned in the boiler system, the domestic water tank must first be filled and pressurized, then the body (outer body) must be filled. When the water is completely drained from the system, first the body, then the reservoir part should be emptied.







 Two-Way Motorized Valve	 Pressure Relief Valve	 Check Valve	 Twin-Head Pump	 Radiator Heating System
 Three-Way Moodulating Motorized Valve	 Pressure Gauge	 Safety Thermostat	 Ball Valve	 Thermometer
 Scald Protection Three-Way Valve	 Drain Valve	 Solar Panel	 Membrane Expansion Tank	 Dirt Separator
 Three-Way Motorized Valve	 Buffer Tank	 Air Separator	 Strainer	 Ball Valve
 Pressure Release Valve	 Bypass Valve	 Air Vent	 Pump	 Underfloor Heating

 Depending on the stiffness of the mains water, CLEANING the lime, dirt and sludge that may form in the resistance and the water heater in certain periods by OPENING flange IS RECOMMENDED in order to always get the desired performance from your device. CHEMICAL CLEANING IS NOT ABSOLUTELY RECOMMENDED while the product is cleaned.

 Except for anode gaskets, the gaskets on the product are disposable gaskets. DO NOT USE THE GASKETS AGAIN WHEN THE PARTS OF THE GASKETS ARE DISASSEMBLED FOR ANY REASON. Contact the seller.

 MAKE SURE THAT the equipments such as valve, check valve, dirt separator, safety valve, expansion tank, thermometer in the installation of the device to be robust.

 Clean the dirt separator by removing the dirt holder(filter) at regular intervals.

 The magnesium anode on the device should be checked for at least TWICE for at least one year and the control frequency to be done according to the number of the anodic wear after the first check is DETERMINED. Magnesium anode finished products are not covered by warranty.

 When the device is deactivated, measures must be taken to prevent freezing and the water heater must be emptied.

 When cleaning the inside of the product, do not damage the internal body covering (enamel) the physical and chemical damage.

 After cleaning the product, the cleaning flange, thermowell, thermostat connection points must be sealed.

Cathodic protection is the stopping of the anodic reactions of metals that come into contact with water and air by occurring on the metal surface by turning an electrochemical cell into a cathode. The cathodic protection that we apply in our water heater is galvanic-based and the anode is the galvanic element. There are some tolerances for enamel coating in the standard DIN 4753-3. These tolerances describe weak zones in the amount of enamel-covered work. The anode task is to prevent corrosion from these regions.

Depending on the product model, the diameter and length of the magnesium anode may vary. In the type of magnesium anode to be used in products, Kodsan has the right to choose and change without informing the customer.

Below are three different anode patterns used in Kodsan branded products;



PLUGGED ANODE



ISOLATED ANODE



ELECTRONIC ANODE





1. TURN OFF the product cold water valve.
2. Open the safety valve or hot water tap to get the pressure from the place. DO NEVER INTERFERENCE WITH THE PRODUCT UNDER PRESSURE.
3. Remove the plastic cap from the top of the product and peel off the anodes with the appropriate tools and / or appliances.
4. Determine your control period according to the magnesium anodisation. The life of the anodes may vary with respect to water structure and galvanic corrosion that may or may not form in time. At suitable water conditions, the life of anode is 2 years, but this can be reduced to 6 months depending on the condition of the water used. Set the control period not less than 2 times per year. Change the magnesium anodes in accordance with the lifetime simulation given in page 30.
5. Assemble the magnesium anodes / anodes with the appropriate tools and household appliances that have supplied the product in varying amounts and types according to the model and volume of the product.
6. The assembled magnesium anodes should be as tight as the need for sealing.
7. Open the cold water valve. You can continue to use your product.

⚠ The anode is not covered by warranty because it is a consumable material.

⚠ Electronic anodes do not need to be changed. MAKE SURE that your electronic anode is permanently connected to the 220V power supply of the power supply line .



PLEASE CONSIDER the results of the following product life simulation during the exchange of your magnesium anodes, which are cathodic protection elements based on galvanic.

APPEARANCE	SITUATION	6 <sup>th</sup> MONTH CONTROL	1 <sup>st</sup> YEAR CONTROL
	%0 UNUSED	Please contact the seller company. Your anode does not function.	Please contact the seller company. Your anode does not function.
	%25 USED	You can determine the control period as once a year.	Tap water conductivity is not suitable.
	%75 USED	You can determine the control period as once a year.	You can determine the control period as once a year.
	%100 ALL OVER	Tap water is not suitable for your water heater. Please contact the seller company.	You can determine the control period as twice a year.

The water you will use in your device is required to be conditioned according to the limit values allowed in the WHO REGULATIONS FOR HUMAN CONSUMPTION WATERS and World Health Organization Guidelines for Drinking-Water Quality, which was published in the Official Gazette dated 07.03.2013 and numbered 28580. If the water used in your device does not comply with the relevant regulations, standard values and limit values (EPA, WHO, etc.) given in documents belonging to internationally accepted organizations, your product will not be covered by the WARRANTY. Some limit values are presented below as an example.

Parameter		Limit Value	Unit
Sodium	Na	200	mg/l
Amonium	NH <sub>4</sub>	0,5	
Manganese	Mn	50	
Iron	Fe	200	
Fluoride	F	1,5	
Chloride	Cl	250	
Nitrate	NO <sub>3</sub>	50	
Nitrit	NO <sub>2</sub>	0,5	
Sulfate	SO <sub>4</sub>	250	
T.Cation / T.Anion	K/A	> 1	

Parameter		Limit Value	Unit
Kadmium	Cd	5	µg/L
Chromium	Cr	50	µg/L
Copper	Cu	2	mg/L
Cyanide	CN	50	µg/L
Plumb	Pb	10	µg/L
Mercury	Hg	1	µg/L
Nickel	Ni	20	µg/L
Aluminium	Al	200	µg/L
Conductivity		2500	20 °C - µS/cm <sup>-1</sup>
pH		≤ 9,5-6,5≤	pH Units

For products that are under warranty, the following procedure is applied for customer satisfaction.

- a. If your device malfunctions, please contact the dealer. Fill in the CUSTOMER RETURNS AND FEEDBACK FORM sent by the seller and send the photograph showing at least 1 mechanical and / or electrical installation to the dealer.
- b. The technical service report and photographs of the defective product are recorded on the spot by the technical service personnel of the seller in order to pass the quality records about the customer complaint.
- c. In the technical service report, the conformity of the installation and installation of the product to the requirements will be considered in the user's manual ABSOLUTELY.
- d. During on-site technical service, the product can BE RECALLED TO OUR FACTORY for the detection of the production / user error even if the location and shape of the error can be seen.
- e. If the defect source can not be detected in place and a new product submission decision is made without expecting destructive / non-destructive inspection results for similar situations, the defective product should be sent to Kodsan within 5 working days. Otherwise, the customer with the product will be invoiced. KODSAN may wait for the time allowed for the destructive / non-destructive inspection results with the relevant Regulations for new product shipments.
- f. The new product is shipped to the customer by Kodsan.
- g. The defective product in the system is disassembled and sent to Kodsan factory. For analysis of faults such as puncture, the product is connected to the test station, after the conditions of the end user are simulated, the product is cut and the drilled region is removed. In such cases, the determination of the shape of the piercing, the direction of the piercing and whether it depends on the water condition is carried out by various visual and / or destructive inspection techniques.

# KODSAN

OSB Karamanlılar Cd No. 10-12 Sincan

06935 ANKARA | TURKEY

T +90 312 267 07 67

T 444 50 39

F +90 312 267 05 54

[export@kodsan.com.tr](mailto:export@kodsan.com.tr)

[kodsan.com.tr](http://kodsan.com.tr)